

PART NO.	"A"±.015	"B"±.060	"C"±.015	HOLDING DIA. "D"±.015
PKKL-3	1.020 [25.9]	.921 [23.4]	.670 [17]	.374 [9.5]
PKKL-3S	.830 [21.1]	.828 [21]	.75 [19.1]	.307 [7.8]
PKKL-4	1.19 [30.3]	1.26 [32]	.76 [19.4]	.532 [13.5]

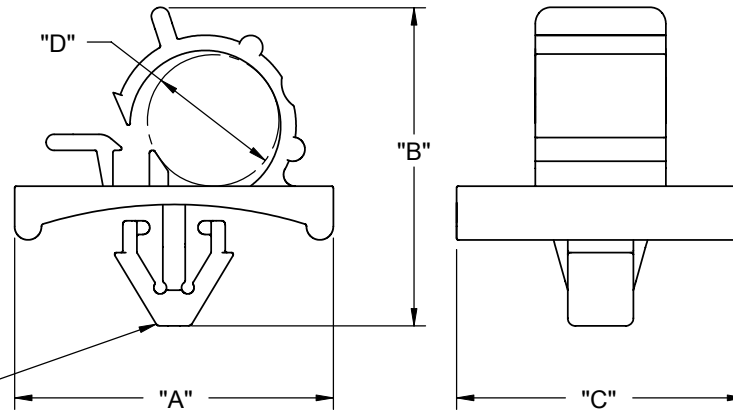

TO SNAP-LOCK IN A .256±.003
[6.5±0.08] DIA. HOLE, IN A
.031-.063 [0.8-1.6] PANEL THICKNESS

NOTES:

1. MATERIAL: NYLON 6/6 UL 94 V-2 (RMS-01)
2. COLOR: NATURAL.
3. ALTERNATE UNITS FOR REFERENCE ONLY

REV.	DESCRIPTION	ENGR.	DATE
B	REDRAWN, SEE ECN #1330 FOR CHANGES	SK	05/30/07
A	CHANGED FILE NO.	SM	08/23/02

TITLE: PLUG-IN KWIK KLIP, LOCKING				DWG IN IN [MM]		FINAL	
CREATED USING SOLIDWORKS		FILE #: PKKL	DWN: SK	APP: SK		PART #	
TOLERANCES UNLESS NOTED XX=±.010 .XXX=±.005 FRAC.=±1/64 ANG.=±1°		SHEET: 1 OF 1	SHEET SIZE: A	DT: 05/30/07	CHKD: SJ	PRINT TYPE	
RE: RICHCO, INC.		RICHCO, INC. ENG@RICHCO-INC.COM (773) 539-4060		SEE TABLE		CA	